

Installation and Operating Instructions

Ventilating Fan

Model No. FV-0510VS1

| Availability of replacement parts, repair services, and information for maintenance or repair | |
|---|--|
| <input type="checkbox"/> | Spares parts |
| <input checked="" type="checkbox"/> | Sub assembly available through authorized parts distributor only |
| <input type="checkbox"/> | Repair services |
| <input checked="" type="checkbox"/> | Limited to sub assembly |
| <input type="checkbox"/> | Information for maintenance or repair |
| <input checked="" type="checkbox"/> | Customer maintenance covered in Owner's Manual |

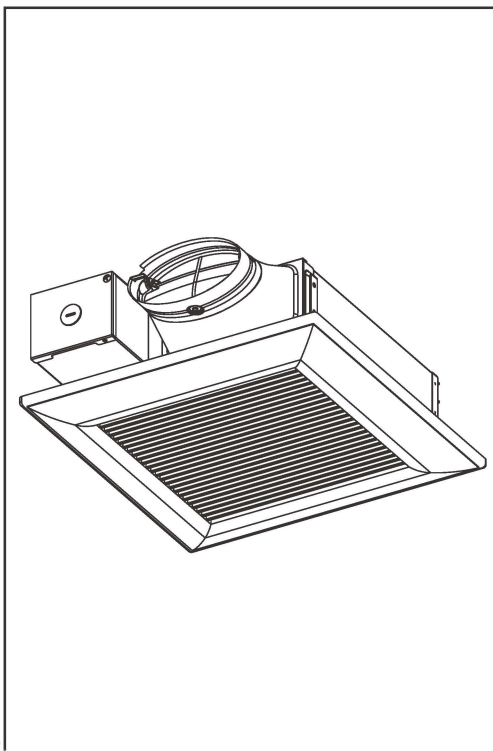

CONTENTS

| | |
|---------------------------------|--------------|
| GENERAL SAFETY INFORMATION | 2~4 |
| DESCRIPTION | 4 |
| UNPACKING | 4 |
| SUPPLIED ACCESSORIES | 4 |
| DIMENSIONS | 4 |
| WIRING DIAGRAM | 5 |
| FEATURE | 5 |
| INSTALLATION I (JOIST MOUNTING) | 5~6 |
| INSTALLATION II (WALL MOUNTING) | 7 |
| MAINTENANCE (CLEANING) | 7~BACK COVER |
| PRACTICAL GUIDE TO INSTALLATION | BACK COVER |
| SPECIFICATIONS | BACK COVER |
| PRODUCT SERVICE | BACK COVER |

READ AND SAVE THESE INSTRUCTIONS

Thank you for purchasing this Panasonic product.

Please read these instructions carefully before attempting to install, operate or service the Panasonic product. Please carefully read the "GENERAL SAFETY INFORMATION" (P.2~4) of this manual before use. Failure to comply with instructions could result in personal injury or property damage. Please explain to users how to operate and maintain the product after installation, and this booklet should be presented to users.

Please retain this booklet for future reference.



GENERAL SAFETY INFORMATION

For Your Safety





To reduce the risk of injury, loss of life, electric shock, fire, malfunction, and damage to equipment or property, always observe the following safety precautions.

Explanation of symbol word panels

The following symbol word panels are used to classify and describe the level of hazard, injury, and property damage caused when the denotation is disregarded and improper use is performed.







| | |
|---|--|
|  WARNING | Denotes a potential hazard that could result in death or serious injury. |
|  CAUTION | Denotes a hazard that could result in minor injury. |
| NOTICE | Denotes a hazard that could result in property damage. |

The following symbols are used to classify and describe the type of instructions to be observed.

| | |
|---|---|
|  | This symbol is used to alert users to a specific operating procedure that must be followed in order to operate the unit safely. |
|  | This symbol is used to alert users to a specific operating procedure that must not be performed. |
|  | This symbol is used to alert users not to disassemble the equipment. |
|  | This symbol is used to alert users to make sure of grounding when using the equipment with the grounding terminal. |

WARNING

To reduce the risk of fire, electric shock or injury to persons, observe the following :

-  Use this unit only in the manner intended by the manufacturer. If you have any questions, contact the manufacturer.
-  Before servicing or cleaning unit, switch power off at service panel and lock the service disconnecting means to prevent power from being switched on accidentally. When the service disconnecting means cannot be locked, securely fasten a prominent warning device, such as a tag, to the service panel.
-  Installation work and electrical wiring must be done by qualified person(s) in accordance with all applicable codes and standards, including fire-rated construction.
-  Sufficient air is needed for proper combustion and exhausting of gases through the flue (chimney) of fuel burning equipment to prevent back drafting. Follow the heating equipment manufacturer's guideline and safety standards such as those published by the National Fire Protection Association (NFPA), and the American Society for Heating, Refrigeration and Air Conditioning Engineers (ASHRAE) and the local code authorities.
-  When cutting or drilling into wall or ceiling, do not damage electrical wiring and other hidden utilities.
-  Ducted fans must always be vented to the outdoors.

GENERAL SAFETY INFORMATION

WARNING

- ! This model is UL listed for tub and shower enclosures.
- ! A statement to the effect that when the product is to no longer be used, it must not be left in place but remove, to prevent it from possibly falling.
- ! Ceiling joist or wall stud must be subjected to static load more than five times the weight of the product.
- ! Install the fan at least 1.5 m (5 feet) above the floor, and the fan must be installed above a counter or major appliances that serves as a barrier.
- ! If this unit is to be installed over a tub or shower, it must be marked as appropriate for the application and be connected to a GFCI (Ground Fault Circuit Interrupter) - protected branch circuit.
- ⏚ The product must be properly grounded.
- ⊘ Do not install with a method which is not approved in the instructions.
- ⊘ Do not use this fan with any solid-state speed control device. Solid state controls may cause harmonic distortion which can cause motor humming noise.
- ⊘ Canada only: Not to be installed in a ceiling thermally insulated to a value greater than R40.
- ⊘ Do not disassemble the unit for reconstruction. It may cause fire or electric shock.

CAUTION

- ! Follow all local electrical and safety codes, as well as the National Electrical Code (NEC) and the Occupation Safety and Health Act (OSHA).
- ! Make sure that the electric service supply voltage is AC 120 V, 60 Hz.
- ! Always disconnect the power source before working on or near the fan, motor or junction box.
- ! Protect the supply wiring from sharp edges, oil, grease, hot surfaces, chemicals or other objects.
- ! The special-purpose or dedicated parts, such as mounting fixtures, must be used if such parts are provided.
- ⊘ Do not install this ventilating fan where interior room temperature may exceed 104 °F(40 °C).
- ⊘ For general ventilating use only. Do not use to exhaust hazardous or explosive materials and vapors.
- ⊘ Do not kink the supply wiring.
- ⊘ Not for use in cooking area. (Fig.A)

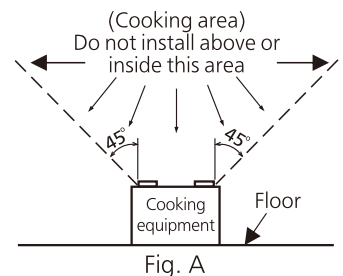

NOTICE

- ! Provide make up air for proper ventilation.
- ⊘ When one switch is connected with two or more products in parallel, the unit may not function. Therefore, parallel connection must not be allowed.

GENERAL SAFETY INFORMATION

NOTICE

 Do not install the product where ducts are configured as shown in below.



Excessive bending



Successive bending



Squeezed duct



Adaptor Bend close to duct adaptor

DESCRIPTION

This product is listed by UL under UL file No. E78414.



This product uses a sirocco fan driven by a DC motor powered by an integral transformer. The motor is designed to have long operating life, high dynamic response, higher speed ranges with saving energy. The grille covering the fan body is a spring-loaded, quick remove type. A damper for preventing air counter flow is provided. The blower uses a high-capacity sirocco fan developed to reduce the noise level.



UNPACKING

Unpack and carefully remove the product from carton.

Refer to the Supplied Accessories list to verify that all parts are present.

SUPPLIED ACCESSORIES

| Part name | Appearance | Quantity |
|-----------------------|---|--------------------|
| Grille |  | 1 |
| Long screw (ST4.2X30) |  | 5 (1 for spare) |

| Part name | Appearance | Quantity |
|---|--|----------|
| Installation and operating instructions |  | 2 |
| Limited warranty |  | 1 |

DIMENSIONS

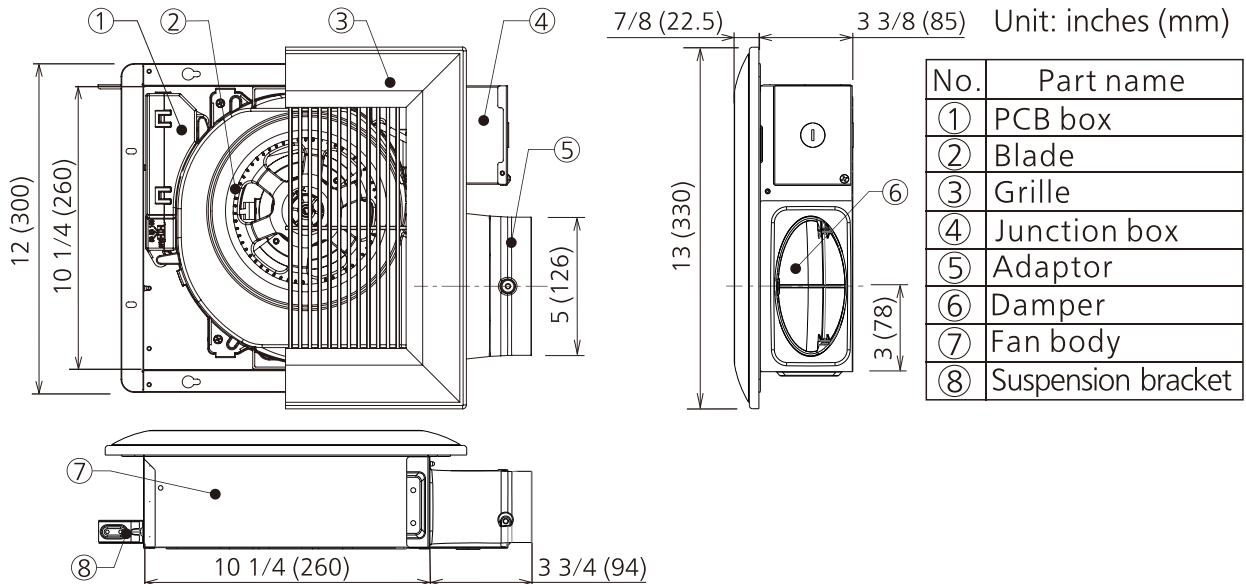

WIRING DIAGRAM

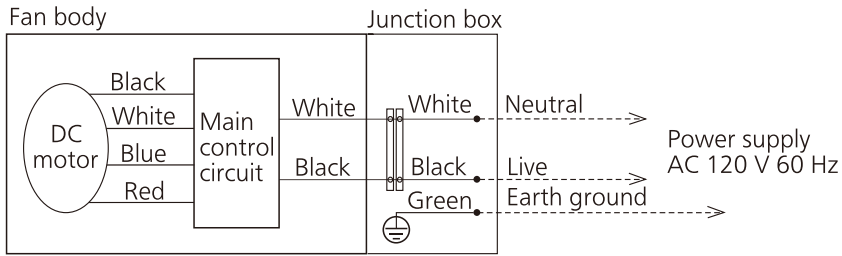

FEATURE

This product employs innovative, state-of-the-art technologies that provide a number of customizable unique features that lead to improved indoor air quality. Please read this manual first in order to realize the benefits of this customizable, modular fan.

Optimum Ventilation Performance:

Duct length, elbows and other factors increase static pressure which can hinder the performance of most ventilation fans. This fan utilizes SmartFlow microchip technology that monitors the static pressure in the system and speeds up or slows down the rpm of the fan depending upon the amount of resistance within the ducts. This feature allows the fan to perform as rated and avoid potential installation issues.

Outstanding Energy Savings:

This product is built using DC motor technology. The DC motor is 30%~70% more energy efficient than the minimum ENERGY STAR requirements.

Pick-A-Flow Feature

This product comes with Pick-A-Flow speed options.

The Pick-A-Flow switch on the face of product allows the option to choose 50, 80, 100 CFM. This product can run continuously or intermittently, depending upon the needs of the owner.

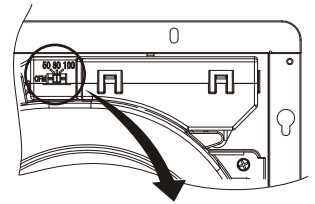

| Air volume option (CFM) | | | Factory setting |
|-------------------------|----|-----|-----------------|
| 50 | 80 | 100 | 80 CFM |

Pick-A-Flow switch



INSTALLATION I (JOIST MOUNTING)

CAUTION

! Please wear gloves to protect hands during the installation as follow.

1. Before installation, please remove the tape which protects damper during shipping and accessory screws from duct adaptor, and check that the damper can open and close smoothly. (Fig.1)

2. Fix the flange of frame to joist by 2 long screws (ST4.2X30), and fix the suspension bracket to joist by 2 long screws (ST4.2X30). (Fig.2)

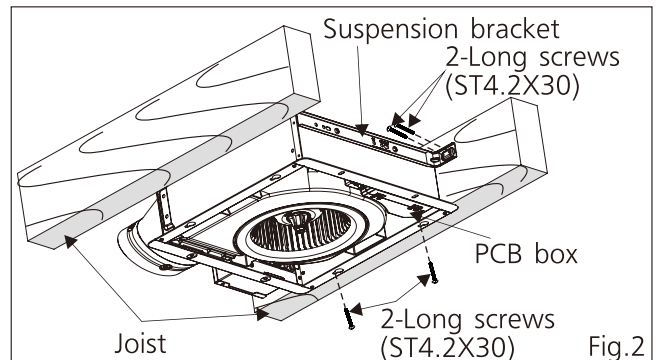
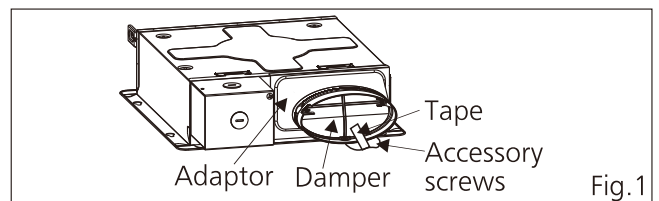

INSTALLATION I (JOIST MOUNTING)

CAUTION

! The screws for fixing suspension bracket should not be replaced by other screws, otherwise the cord in PCB box may be damaged and cause fire.

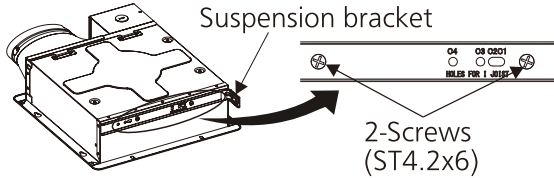

3. Remove junction box cover and secure conduit or stress relief to junction box knock-out hole. (Fig.3)
4. Refer to wiring diagram (P.5), follow all the local electrical safety codes as well as the National Electrical Code (NEC). Using UL approved wire nuts, connect house power wires to ventilating fan wires. (Fig.3)

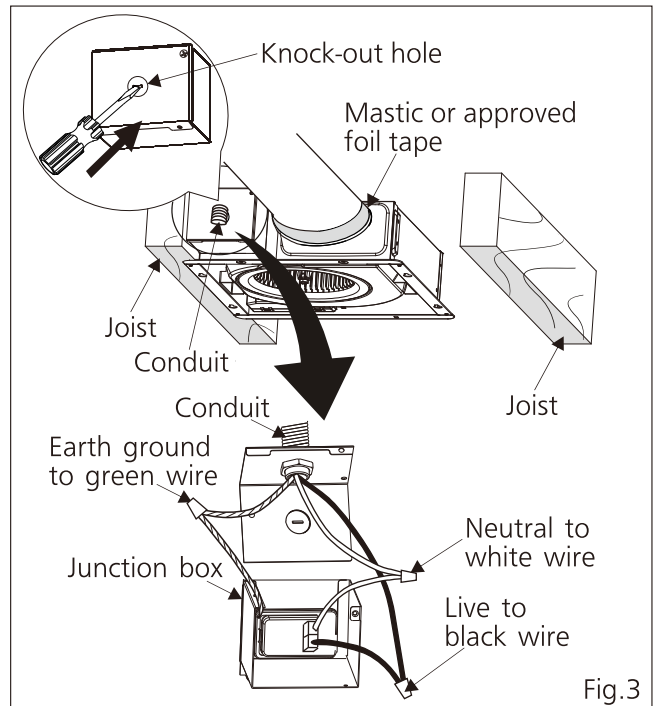

CAUTION

! Mount junction box cover carefully so that lead wires are not pinched.

5. A 4 inch circular duct is needed to connect to the relevant part of adaptor. Squeeze a circular exhaust duct to fit the adaptor, then slip it onto adaptor and secure it with clamps, or ties and seal it with mastic or approved foil tape. (Fig.3)

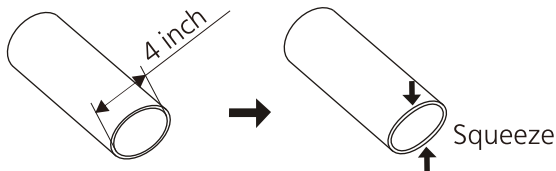

Note:

If using 3 inch round duct, please purchase the 26 gauge steel Panasonic 4" Oval - 3" Round reducer from our representative.

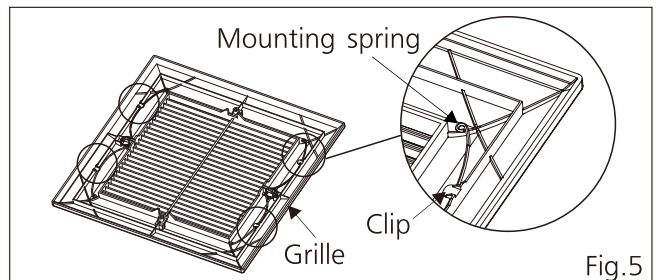
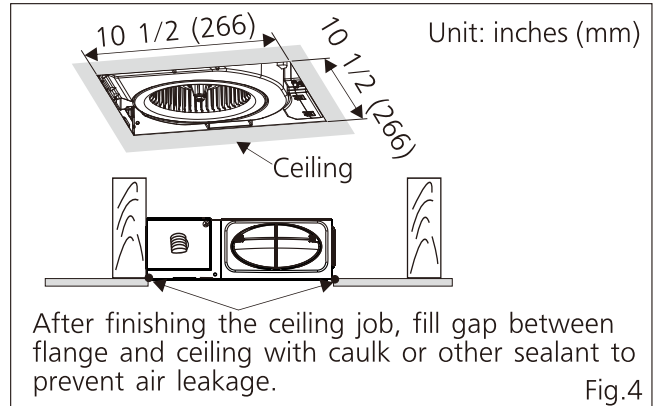

6. Finish ceiling work. Ceiling hole should be aligned with the inside edge of the flange. (Fig.4)

7. Take out the mounting springs of grille from clips. (Fig.5)

8. Insert the mounting springs into slots as shown and mount grille to fan body. (Fig.6)

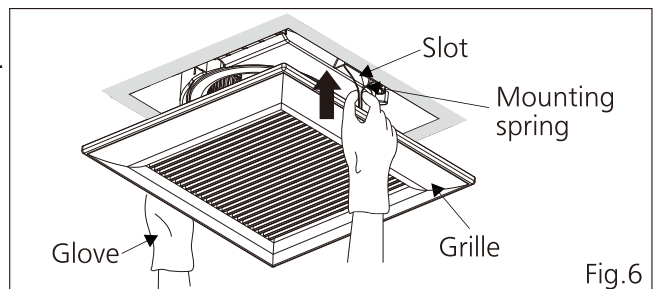

INSTALLATION II (WALL MOUNTING)

1. Before installation, please refer to step 1 of INSTALLATION I. (P.5)
2. Fix the flange of frame to stud by 2 long screws (ST4.2X30), and fix the suspension bracket to stud by 2 long screws (ST4.2X30). (Fig.7)

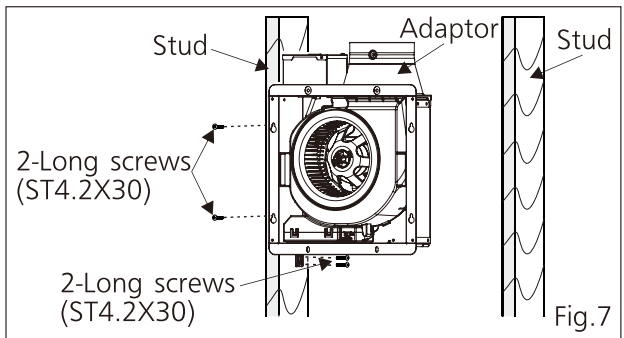

CAUTION

! The adaptor of product must be installed upward. (Fig.7)

3. Complete the wiring and duct work, please refer to step 3 to 5 of INSTALLATION I. (P.6)
4. Finish the wall work. Wall hole should be aligned with the inside edge of the flange. (Fig.8)
5. Install the grille, please refer to step 7 to 8 of INSTALLATION I. (P.6)

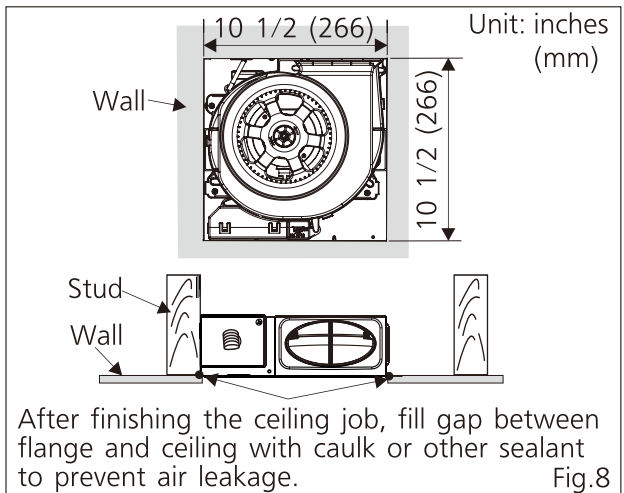

MAINTENANCE (CLEANING)

WARNING

! Disconnect power source before working on unit.

CAUTION

! Routine maintenance must be done every year. Please wear gloves during the cleaning work.

⊘ Do not immerse motor in water when cleaning.

NOTICE

⊘ Do not soak resin parts in water over 140 °F (60 °C).

⊘ Never use gasoline, benzene, thinner or any other such chemicals for cleaning the fan.

1. Remove grille. (Squeeze mounting spring and pull down carefully) (Fig.9)
2. Wash and clean grille. (Don't put into hot water. Use non-abrasive kitchen detergent, wipe dry with clean cloth) (Fig.10)

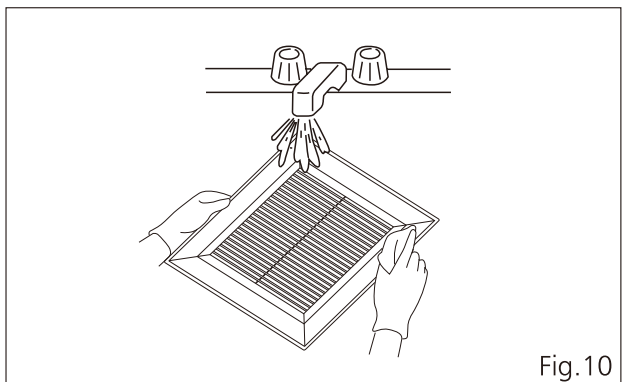
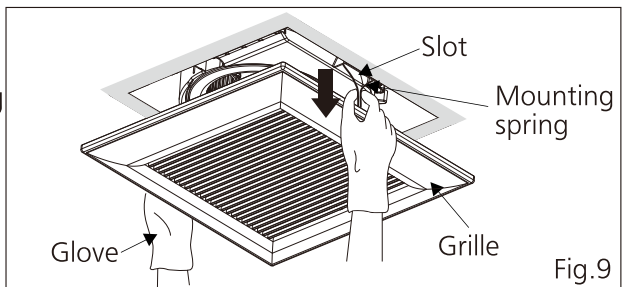

MAINTENANCE (CLEANING)

3. Remove dust and dirt from fan body using a vacuum cleaner. (Fig.11)
4. Using a cloth dampened with kitchen detergent, remove any dirt from fan body. Wipe dry with clean cloth. (Fig.12)
5. Reinstall grille, please refer to step 8 of INSTALLATION I. (P.6)

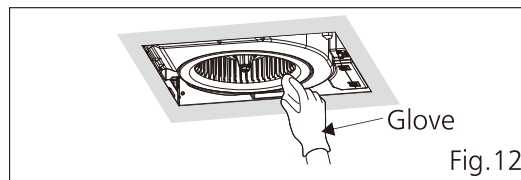
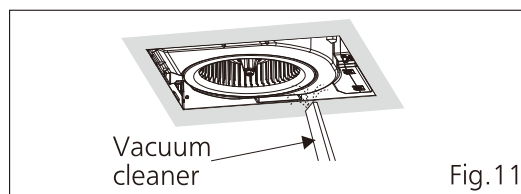

PRACTICAL GUIDE TO INSTALLATION

Properly insulate the area around the fan to minimize building heat loss and gain. (Fig.13)

Loose fill or batt insulation can be placed directly over the fan housing in the attic. Our fans and fan/light combination units do not create excessive heat that is a common problem with recessed light fixtures or some competitor's fan/light combination. Our efficient, cool-running motors and our LED lighting unit do not create enough ambient heat to be subjected to these limitations.

The ducting from this fan to the outside of the building has a strong effect on the air flow, noise and energy use of the fan. Use the shortest, straightest duct routing possible for best performance, and avoid installing the fan with smaller ducts than recommended. Insulation around the ducts can reduce energy loss and inhibit mold growth. Fans installed with existing ducts may not achieve their rated air flow.

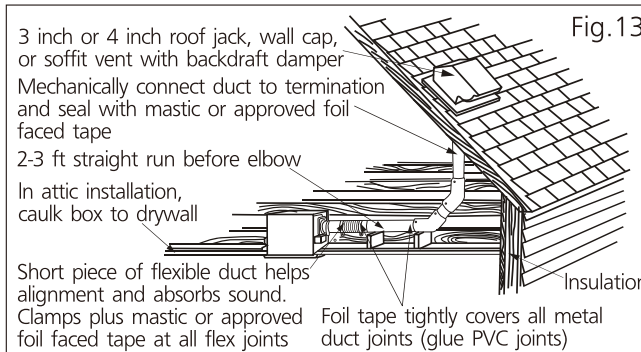

SPECIFICATIONS

| Model No. | Air direction | Voltage (V) | Frequency (Hz) | Duct diameter (inches) | Air volume at 0.1" WG (CFM) | Noise (sones) | Speed (rpm) | Power (W) | Weight lb.(kg) |
|------------|---------------|-------------|----------------|------------------------|-----------------------------|---------------|-------------|-----------|----------------|
| FV-0510VS1 | Exhaust | 120 | 60 | 4 | 50 | <0.3 | 708 | 4.4 | 6.8 (3.1) |
| | | | | | 80 | 0.4 | 797 | 7.2 | |
| | | | | | 100 | 0.9 | 902 | 11.1 | |

HVI Certified performance based on HVI Procedures 915, 916, and 920.

PRODUCT SERVICE

Warning Concerning Removal of Covers. The unit should be serviced by qualified technicians only. Your product is designed and manufactured to ensure a minimum of maintenance. Should your unit require service or parts, call Panasonic Call Center at 1-866-292-7299 (USA) or 1-800-669-5165 (Canada).

Panasonic Corporation of North America

Two Riverfront Plaza, Newark, NJ 07102
www.panasonic.com

© Panasonic Corporation 2016

Panasonic Canada Inc.

5770 Ambler Drive, Mississauga, Ontario L4W 2T3
www.panasonic.com